

Variable Optical Attenuators (mVOA-C1)

MAP Series Metrology Grade Optical Attenuator

The Multiple Application Platform (MAP series) Variable Optical Attenuator (mVOA-C1) is a stepper motor and filter-based attenuator that delivers metrology-grade programmable attenuation performance in the industry's most compact package.

With more than 30 years of leadership in high-performance attenuators for lab and manufacturing applications, the mVOA-C1, is now in its fifth generation. The mVOA is a high-resolution, wide wavelength-range attenuator ideal for use in applications such as amplifier testing, 100/400GE client optic testing and stressing advanced next generation coherent long haul interfaces. The attenuator is built on proven industry leading technology for maximum reliability and performance.

The module is available in single-mode or multimode fiber, supports multiple optical connectors and has versions with either an output tap or integrated power meter control. The power control option can function as an in-line power monitor. It is available in single, dual, or quad configurations, all in single slot modules. Up to 48 independently controlled attenuators can be installed in a single 8-slot MAP chassis.

The MAP variable optical attenuator is hot-pluggable and designed for use with all versions of the MAP series chassis family

The mVOA has low, industry leading, insertion loss (<0.9 dB) and exceptional spectral and attenuation uniformity, thus minimizing loss budget. Making the mVOA ideal for CWDM and DWDM test applications. The attenuation accuracy (± 0.01 dB) and repeatability (± 0.015 dB) are key to enabling manufacturing test systems that maximize test yield.



KEY FEATURES

- Ultra-low insertion loss (<0.9 dB) and outstanding spectral uniformity minimize loss budget utilization
- Fastest transition speed and settling time in its class reduces testing time
- Optional built-in power monitor provides comprehensive closed-loop power control settings
- Optional higher power capability can withstand up to 2W input power for single mode fiber (500 mW for multimode fiber)

KEY APPLICATIONS

- High accuracy and high repeatability reduces measurement uncertainty
- Flat spectral response reduces wavelength dependent uncertainty in CWDM and DWDM multi-wavelength applications
- Low back-reflection
- Optional built-in wavelength calibrated power meter
- High input power capability for EDFA testing and multi-wavelength applications

COMPLIANCE

- Complies with CE, CSA/UL/IEC61010-1, plus LXI class C requirements when installed in a MAP chassis

Functional Description

The mVOA provides attenuation through an expanded beam modified by a linearly variable neutral density filter. Precision optical design, optimized over 30 years, is key to guaranteeing low IL/RL and PDL. Management of the attenuated light is carefully considered in order to ensure high power performance and long-term reliability. Proprietary motor control algorithms paired with a kinematic drive delivers high speed attenuation change with industry leading settling time and stability

There are two modes of operation, attenuation mode and power mode. Attenuation mode, the most basic form of operation, changes the insertion loss of the module without consideration for the input power. Power mode sets the absolute power at the output of the mVOA and requires the internal power meter option. When in power mode, input power tracking can be enabled, which automatically adjusts the mVOA to keep the output power constant. Multiple power and attenuation offsets are available to compensate for test system losses and simplifies test system integration.

An intuitive graphic user interface (GUI) is optimized for use in either a laboratory or a manufacturing environment. Efficient transition between summary and detailed views (figure 1 and figure 2) allow users to operate at a system level or access the full power of a module.



Figure 1 - mVOA MAP-300 summary view GUI

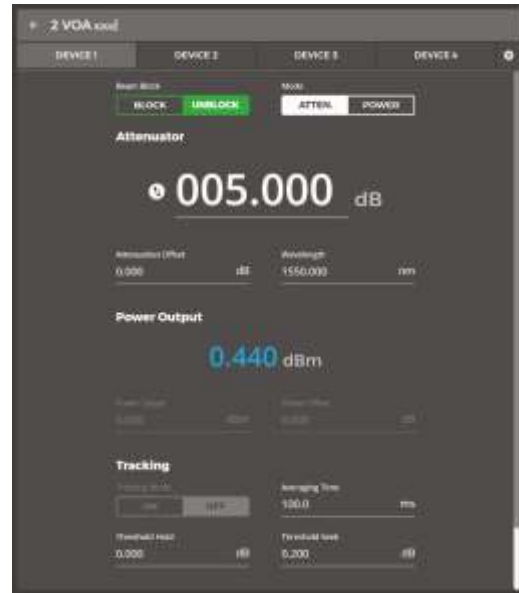

Figure 2 - mVOA MAP-300 detailed view GUI

Options and Configurations

The mVOA can be configured in three possible ways,

- 1. Standard attenuator (figure 3a):** This configuration operates in attenuation mode only. To control output power, measurement of the input power is required prior to testing.
- 2. Attenuator with output tap (figure 3b):** This configuration operates in attenuation mode only. An output tap (5% for single mode and 10% for multimode) allows the output power to be monitored on an external power meter.
- 3. Attenuator with output power monitoring (figure 3c):** This configuration operates in either attenuation or output power mode. Output powers can be set directly. When tracking is enabled the attenuator dynamically adjusts for input power changes.

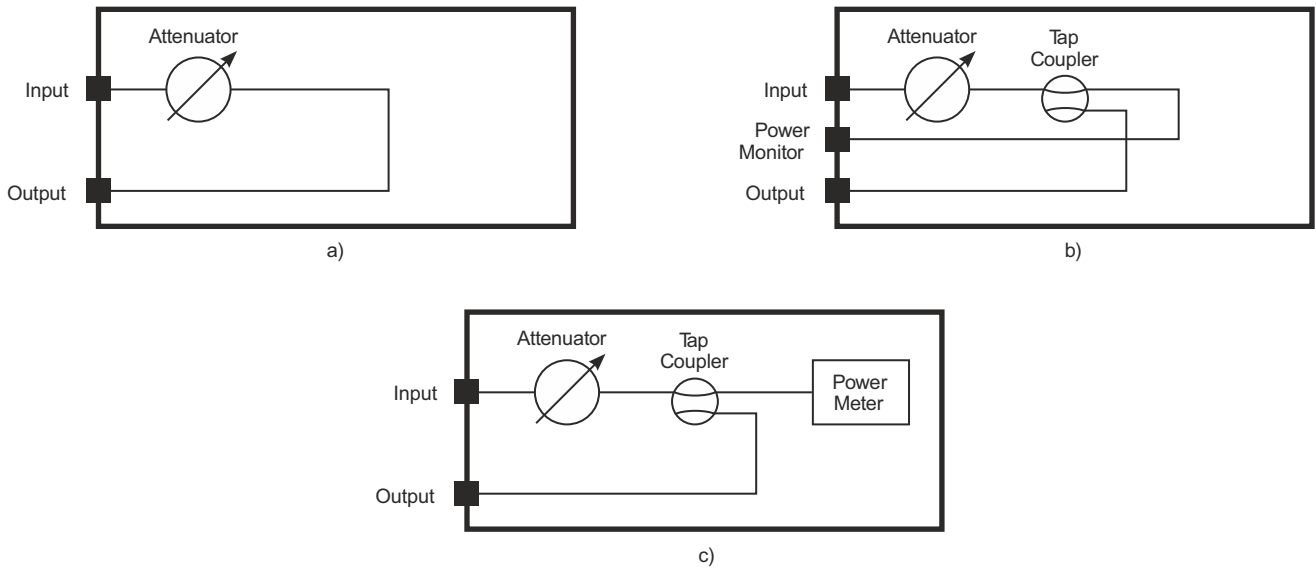

Figure 3 – Optical Configurations of the mVOA module, a) Standard attenuator; b) Attenuator with output tap; c) Attenuator with output power monitoring

Chassis and Modular Family

The VIAVI Multiple Application Platform (MAP) is a modular, rack mountable or benchtop, optical test and measurement platform with chassis' that can host 2, 3 or 8 application modules. The LightDirect family of modules are characterized by their simple control and single function nature. Individually or together they form the foundation of a diverse array of optical test applications. The web enabled multiuser interface is simple and intuitive. LXI compliant with a full suite of SCPI based automation drivers and PC based management tools, the VIAVI MAP is optimized for both the lab to manufacturing environments

The mVOA is part of the LightDirect module family. Alongside the many other modules, such as light sources, polarization scramblers, power meters, and spectrum analyzers, the MAP series is the ideal, modular platform for photonic system and module testing.

The mVOA is compatible with all current MAP-300 and MAP-200 chassis.



Light Direct

Specifications

Parameters	Single-Mode		Multimode	
	Standard	With Output Power Monitor	Standard	With Output Power Monitor
Insertion loss at 0dB ^{1,2,3,4}	≤0.9 dB (≤1.5 dB tap option)	≤1.5 dB	≤1.5 dB (≤2.4 dB tap option)	≤2.4 dB
Polarization-dependent loss ⁵	≤ 0.08 dB (≤0.15 dB tap option)	≤0.15 dB	N/A	
Return loss ^{1,2,6}	≥55 dB		≥45 dB	
Maximum input power ⁹ (standard power/high-power option)	+23 dBm/+33 dBm		+23 dBm/+27 dBm	
Wavelength range	1260 to 1650 nm		750 to 1350 nm	
Attenuation range ^{1,2}	70 dB		65 dB	
Shutter isolation	≥80 dB		≥75 dB	
Attenuation flatness ^{8,10}	±0.04 dB		N/A	
Attenuation slew rate	≥25 dB/s		≥20 dB/s	
Relative attenuation uncertainty ^{1,2,3,7,10,11,13}	±0.1 dB			
Attenuation repeatability ^{3,7,11,13}	±0.01 dB			
Attenuation resolution ¹⁴	0.001 dB			
Attenuation settling time	≤55 ms			
Closed-loop power range ^{1,2} (standard power/high-power option)	N/A	+11 to -49 dBm / +31.5 to -28.5 dBm	N/A	+5 to -40 dBm
Power monitor linearity ^{1,2,3,10}	N/A	±0.03 dB	N/A	±0.03 dB
Power setting repeatability ^{1,2,10}	N/A	±0.015 dB	N/A	±0.015 dB
Power setting resolution	N/A	0.001 dB	N/A	0.001 dB
Warm-up time	30 min			
Operating temperature	0 to 50°C			
Storage temperature	-30 to 60°C			
Operating humidity	15 to 80% RH, 0 to 40°C noncondensing			
Dimensions (W x H x D)	4.1 x 13.3 x 37.0 cm			
Weight	1.1 kg (single) / 1.3 kg (dual) / 1.7 kg (quad)			
Warranty	3 Years			
Calibration period	3 Years			

1. At both 1550 ±15 nm and 1310 ±15 nm for single-mode.
2. At both 850 ±15 nm and 1310 ±15 nm for multimode.
3. +23/-5°C only.
4. Excludes connectors, add 0.2 dB typically for connectors.
5. For 0 to 25 dB.
6. Return loss excludes connectors.
7. For range of 0 to 45 dB.
8. For range of 0 to 30 dB over 1480 to 1640 nm.
9. Input to output port only.
10. For light with DOP <5%.
11. For low-coherence laser source (>500 MHz).
12. Consecutive measurements.
13. Relative to 0 dB position.
14. 0 to 65 dB for single-mode, 0 to 50 dB for multimode.

Ordering Information

All mVOA-C1 attenuators are configured by a single part number that defines the function and options of the module. The XXX code defines the fiber type, as seen in table 1, and the YY code defines the connector type, as seen in table 2.

Available Configurations

Power Type	Order Code	Description
Standard Power	MVOA-C1SS0-MXXX-MYY	Single VOA, Standard Power, No Option
	MVOA-C1DS0-MXXX-MYY	Dual VOA, Standard Power, No Option
	MVOA-C1QS0-MXXX-MYY	Quad VOA, Standard Power, No Option
	MVOA-C1SSM-MXXX-MYY	Single VOA, Standard Power, Monitor Option
	MVOA-C1DSM-MXXX-MYY	Dual VOA, Standard Power, Monitor Option
	MVOA-C1QSM-MXXX-MYY	Quad VOA, Standard Power, Monitor Option
	MVOA-C1SS1-M100-MYY	Single VOA, Standard Power, Tap Option, Single Mode Fiber
	MVOA-C1DS1-M100-MYY	Dual VOA, Standard Power, Tap Option, Single Mode Fiber
	MVOA-C1QS1-M100-MYY	Quad VOA, Standard Power, Tap Option, Single Mode Fiber
High power	MVOA-C1SH0- MXXX-MYY	Single VOA, High Power, No Option
	MVOA-C1DH0- MXXX-MYY	Dual VOA, High Power, No Option
	MVOA-C1SHM- MXXX-MYY	Single VOA, High Power, Monitor Option
	MVOA-C1DHM- MXXX-MYY	Dual VOA, High Power, Monitor Option
Licenses	MSUP-300A-4VOAPWC	MAP-300 License to enable 4 VOA cassettes to use external power control
	MSUP-300A-8VOAPWC	MAP-300 License to enable 8 VOA cassettes to use external power control

Table 1

XXX code	Fiber Type
M100	9µm Single Mode
M101	50µm (Om3)
M102	62.5µm (OM1)

Table 2

YY Code	Connector Type
MFP	FC/PC
MFA	FC/APC
MSC	SC/PC
MSU	SC/APC
MLC	LC/PC
MLU	LC/APC

Accessories

Accessories (Optional)	Product and description	
Inspection and cleaning tools	CleanBlastPRO	The patented VIAVI Solutions® CleanBlastPRO fiber end-face cleaning system provides a fast, effective, and cost-efficient solution for removing dirt and debris from connectors in most common applications.
	FiberChek probe microscope	One-button FiberChek Probe delivers a reliable, fully autonomous, handheld inspection solution for every fiber technician.
	P5000i fiber microscope	Automated Fiber Inspection & Analysis Probe provides PASS/FAIL capability to PC, laptops, mobile devices and VIAVI test solutions.
Replacement Parts	Mating sleeves	AC500; FC/PC-FC/PC Universal Connector Adapter
		AC501; FC/PC-SC/PC Universal Connector Adapter
		AC502; FC/APC-FC/APC Universal Connector Adapter
		AC503; FC/APC-SC/APC Universal Connector Adapter
Detector Adaptor	A complete range of single ferrule, duplex, and bare fiber power meter adaptor are available at VIAVI. Refer to the AC adaptor selection guide for more information.	