

# TimeProvider 4100 Series Release 2.3

**Precise Timing Grandmaster  
With Gateway Clock, High  
Accuracy and Redundancy**



## Key Features

- IEEE 1588 v2 PTP grandmaster
- Redundancy via software mechanism using two units with health monitoring of active and standby devices
- Synchronous Ethernet (SyncE) including enhanced ESMC and eEEC G.8262.1
- Global Navigation Satellite System (GNSS) with multi-constellation support (Global Positioning System (GPS), Globalnaya Navigazionnaya Sputnikovaya Sistema (GLONASS), BeiDou Navigation Satellite System (BDS), Quasi-Zenith Satellite System (QZSS) and Galileo) and Satellite-based Augmentation System (SBAS) support
- GNSS with multi-band L1/L2/E5B support
- Primary Reference Time Clock (PRTC) Class A (100 ns) and Class B (40 ns)
- Enhanced PRTC (ePRTC) ITU-T G.8272.1, 30 ns accuracy
- Reliable fanless passive thermal operation
- Oscillator options: mini oven-controlled crystal oscillator (OCXO), OCXO, super OCXO and Rubidium (Rb)
- IPv6/IPv4 on all ports including Management (OAM)
- Standard base unit with eight Ethernet ports, four E1/T1 ports, one craft port, two 1 PPS/ToD ports, two 1 PPS/10 MHz ports
- Optional internal expansion module with 16 E1/T1 ports for a total of 20 E1/T1 outputs per unit with support for composite clock including Japan format
- Optional internal expansion module with four small form-factor pluggable (SFP) and four enhanced small form-factor pluggable (SFP+) for 10 GbE support, 100 Mbps Fast Ethernet and 1 GbE fanout
- Support for multiple IEEE 1588 v2 profiles per unit and per port
- Support of Inband management with PTP Services. Device management, PTP Server, and PTP client on the same physical port to save cost
- Support for high-performance multidomain boundary clock with class C and D accuracy (operation modes)
- High performance: 1,000 PTP unicast clients at max profile rate of 128 PPS and NTP reflector (NTPr) 20,000 tps per port, for a total of 160,000 tps per unit and NTPd at 500 tps on three ports for a total of 1,500 tps per unit
- Fully supports ITU-T profiles for time and phase synchronization: G.8265.1, G.8275.1, and G.8275.2
- Fully supports other legacy and enterprise PTP profiles: Telecom-2008 and Default. L2, IPv4, and Ipv6
- ITU-T G.8273.4 APTS with patented enhanced automatic asymmetry compensation (AAC) over multiple network variations with multiple PTP client inputs and majority vote mechanism
- Security via enhanced SSH and Terminal Access Controller Access-Control System (TACACS+), Remote Authentication DialIn User Service (RADIUS), authentication, authorization and accounting (AAA)
- Radius two-factor authentication
- IEEE 1588 2.1 2019 security support for prong C (architecture guidance) and prong D (monitoring and management)
- Monitoring and measurement capabilities for phase (PTP) and legacy ports
- TimePictra synchronization management system support

## New 2.3 Version Highlights

- Revised E1/T1 expansion module with Composite Clock (CC) and Japan Composite Clock (JCC)
- Precision Time Protocol (PTP) enhancements with higher capacity up to 1,000 clients, dual PTP Server profiles per port
- Enhanced resiliency with multiple PTP inputs and IEEE 1588 2.1 2019 majority vote with enhanced Assisted Partial Time Support (APTS)
- Security enhancements with Authentication, Authorization and Accounting (AAA) support, two-factor authentication and IEEE1588-2019 security prongs
- Enhanced performance with TimePictra Synchronization Management System for status and configuration support
- Enhanced Frequency monitoring with TIE, MTIE and TDEV with configurable masks and standard masks
- Redundancy mode is added to ePRTC operation-mode to bring additional resiliency

## Benefits

- Flexibility to leverage legacy and new investments
- Mitigates impact of backhaul noise, packet delay variation and asymmetry
- High-accuracy phase distribution over long-haul optical networks
- Preserves current Multiprotocol Label Switching (MPLS) network engineering

## Applications

- Sync solution for the mobile edge: 4G/ LTE, Cloud RAN (C-RAN), 5G, Open RAN (O-RAN)
- Ethernet backhaul, midhaul, fronthaul networks
- Cable remote physical layer (R-PHY)
- Migration from legacy synchronization (SONET/SDH) to Ethernet and IEEE 1588 PTP for utilities, transportation and government markets

## Best-of-Breed Server Clock

The TimeProvider 4100 server is a best-in-class 1588 grandmaster complemented by extensive port fan-out for PTP, Network Time Protocol (NTP), SyncE and legacy Building Integrated Timing Supplies (BITS).

With multiple ports for current, legacy and future networks that can be connected to multiple base stations for 4G and 5G deployments, the device is cost-effective solution that can be easily adapted for a wide variety of use cases.

The TimeProvider 4100 series is an industry-leading grandmaster clock with a base model that offers multiple PTP profiles per unit, supporting IEEE 1588 v2 frequency, time and phase profiles such as Telecom 2008, G.8265.1, G.8275.1 and G.8275.2.

The TimeProvider 4100 series SyncE supports enhanced ESMC via extended QL TLV formats per ITU-T G.8264 Amendment 1 (03/2018) Clause 11.3.1.2. It now supports enhanced SSM codes, cascaded eEECs (G.8262.1) add other extensions provided by the latest Quality Level (QL) Threshold Limit Value format.

The TimeProvider 4100 series is based on our newest platform and our latest-generation packet engine to provide the utmost flexibility to support multiple packet services in the box, to specify the service on each port (server, client, probe, NTP), and to select management and client service on either an RJ45 or an SFP port, depending on the network and preference. This flexibility enables operators to select from the number and types of ports and interfaces for specific use cases including 5G, cRAN and Data Over Cable Service Interface Specifications (DOCSIS) remote PHY so they can deploy and scale their equipment without compromising on performance or features.

## Primary Reference Time Clock

The TimeProvider 4100 series meets stringent precise time standards and complies with Primary Reference Time Clock (PRTC) Class A (100 ns) and Class B (40 ns), as well as the latest time and phase standards.

PRTC Class B use cases

- $\pm 130$  ns fronthaul PRTC at Distribution Unit (DU), Time Error (TE)  $\pm 40$  ns
- Time-Sensitive Networking (TSN) network removes extraneous source clock noise
- Smart city Positioning, Navigation, and Timing (PNT) connected vehicles, fast User Equipment (UE) detection

## Oscillator Options

The standard TimeProvider 4100 server is equipped with a crystal oscillator that enables accurate timing within nanoseconds when using GNSS-based time synchronization. However, if GNSS connectivity is lost and the server is placed in holdover, the oscillator will begin to drift, which will impact timing accuracy.

Upgrading the oscillator will significantly improve the holdover accuracy. For example, consider the drift rates listed in the following table for the OCXO, super OCXO and Rubidium upgrades.

## Typical Timekeeping in Holdover

Time Keeping	200 ns	400 ns	1.1 $\mu$ s	1.5 $\mu$ s	5 $\mu$ s	10 $\mu$ s
OCXO	4 hour	8 hours	14.5 hours	16.5 hours	1.5 days	2 days
Super OCXO	11 hours	18 hours	43 hours	52 hours	4.4 days	6.6 days
MAC Laser Driven Rubidium	1 days	1.8 days	3.6 days	4.3 days	8 days	12 days

Note: The above are typical (1 Sigma Confidence) values and include initial phase and frequency errors. Assume a benign temperature environment and that the TP4100 is powered up for three weeks and locked to GNSS for 96 hours.

Frequency	Aging After 30 Days	Aging With Learning	Temperature Stability
OCXO	$\pm 6e-11$ per day	$\pm 3e-11$ per day	$\pm 4e-10$
Super OCXO	$\pm 6e-11$ per day	$\pm 3e-11$ per day	$\pm 4e-10$
MAC Rubidium	$\pm 1e-10$ per month	$\pm 2e-12$ per day	$\pm 5e-11$

The TP4100 is assumed to be powered up for three weeks and locked to GNSS for 96 hours for aging with learning frequency performance category.

Upgrading the oscillator ensures that the TimeProvider 4100 server will continue to serve very accurate PTP and NTP services if the GNSS signal is lost. This allows plenty of time to correct the problem with no degradation or disruption in time synchronization accuracy.

The TimeProvider 4100 server comes with a mini OCXO. This provides the necessary flexibility to select the OCXO, Super OCXO or Rubidium model depending on deployment needs.

Rubidium oscillators are unequalled for telecom applications.

## Small-Form-Factor Rubidium Oscillator



There are compelling reasons to use a Rubidium oscillator instead of an OCXO, but not all Rubidium oscillators are equal. Our miniature Rubidium clocks are available in a unique physics package based on the Coherent Population Trapping (CPT) atomic clock. These devices consume less power, operate over a wide range of temperature operations and have longer life cycles than legacy lamp-based Rubidium oscillators used in other products.

Rubidium oscillators have much better power-on stabilization times than OCXOs: 24 hours after power-up versus 2 to 5 weeks. This differentiation alone is a significant reason for using Rubidium-based units over OCXO-based units.

## GNSS Support

The TimeProvider 4100 series includes a 72-channel GNSS receiver coupled with our patented active thermal compensation technology. Its GNSS satellite input provides flexible support for constellations of choice depending on the region. The TimeProvider 4100 series supports GPS, GLONASS, BeiDou, Galileo, QZSS and SBAS in its standard version. It is configured to support a single band by default.

The TimeProvider 4100 server also provides multi-band support with an enhanced GNSS receiver.

Ionospheric conditions depend on time, season and solar activity. These ionospheric conditions can lead to substantial errors (around 50 ns in some cases) which need to be compensated. A multi-band GNSS receiver allows you to design software that can mitigate these error conditions.

A multi-band receiver can also mitigate jamming. If one frequency is being jammed, the other band can be used for continued operation.

The webGUI on a TP4100 unit displays bar charts with the respective satellite signal values for all five constellations in parallel and as well as for dual frequencies.

## High Performance

The TimeProvider 4100 series can support 1,000 clients at maximum profile rate of 128 packet per second (PPS) with or without twostep clock. It also delivers high-performance NTP support with NTP hardware time stamping at of 20,000 Transactions Per Second (tps) per port, for a total of 160,000 tps per unit, or with NTPd at 500 tps on three ports for a total NTPd performance of 1,500 tps per unit.

## Flexible Architecture

The TimeProvider 4100 series supports PTP, NTP and legacy frequency timing applications. The clock features four BITS ports (E1/T1), two 1 PPS/ ToD ports, two 1 PPS/10 MHz ports, one GNSS port and one craft port. Complementing its advanced feature set, the TimeProvider 4100 series offers optional expansion modules based on customer needs and deployment scenarios. Flexibility is of the utmost importance for enabling operators to select appropriate package, options and interfaces for their respective use cases and deployment models.

## Optional Expansion Modules

The TimeProvider 4100 series provides the necessary flexibility to add internal expansion modules for various capabilities. The expansion module is an optional upgrade to the base unit.

### E1/T1 Expansion Module



The E1/T1 internal module with 16 E1/T1 ports brings the unit to a total maximum of 20 E1/T1 ports (four in the base and 16 in the expansion module).

This expansion module also supports CC and JCC, including two CC/JCC inputs to support cutovers from legacy SSUs.

Ports are configurable as E1, T1, CC and JCC outputs. Two ports can be configured for the CC/JCC input to use for phase alignment during cutovers from legacy Synchronization supply units (SSU).

For needs beyond 40 E1/T1 ports, a TimeProvider 4100 server can be connected to an SSU or Building Integrated Timing Supply (BITS) system as a server reference with full Primary Reference Clock (PRC) traceability.

### 1 GbE/10 GbE Expansion Module



The 1 GbE/100 Mbps/10 GbE expansion module provides 1 GbE fanout and 10 GbE support. The module features four SFP and four SFP+ ports to enable a combination of four 100 Mbps Fast Ethernet and four 1 GbE ports, or eight 1 GbE ports, or a combination of four 1 GbE ports and four 10 GbE ports. As networks evolve, 10 GbE has become more prevalent, so this internal fanout capability is critical to connect to newer network elements.

## Cascading of Units

The TimeProvider 4100 series is designed to enable cascading units for higher density applications and use cases. It can leverage a subtenancy architecture which allows a client unit to subtenant from a server using a ToD input/output. The server, which we recommend be upgraded to use a Rubidium atomic clock, is connected to GNSS constellations while the client TimeProvider 4100 device can use a lower-cost oscillator without connectivity to GNSS. This architecture doubles the port count of the combined system. Units can crossconnect and can also connect to GPS, which enables a second reference when GNSS goes down.

## Resilient Solution

The TimeProvider 4100 series uses a passively cooled design with no fans, which minimizes the risks associated with rotation or moving parts. It also features passive heat sinks for thermal mitigation.

The TimeProvider 4100 series features layered protection and accepts PTP input with our enhanced asymmetry compensation to provide best-in-class APTS to back up the GNSS signal by correcting for up to 32 network path or behavior variations. APTS is a key technology that accounts for high packet delay variation, timing jitter variation and asymmetry challenges.

The TimeProvider 4100 series supports up to three PTP client instances with majority vote mechanism (part of IEEE 1588 2.1 2019 prong C) to select the best input for APTS.

As an additional layer of protection, the TimeProvider 4100 series features optional oscillator upgrades for enhanced holdover performance.

It also provides dual Direct Current (DC) input for power redundancy and geographical network redundancy for failover.

## Redundancy

Software redundancy enables a cost-effective redundancy architecture, flexibility, resiliency and investment protection.

In this software redundancy schema, two units effectively act as a single coordinated system for high availability of Ethernet timing services. One unit is configured as Active while the second unit is set up as standby. Both hardware units need to be similar except for the oscillator grade, which can be lower-grade on the standby unit. License options need to be equivalent on both units.

Both units need to be connected via a direct fiber and additional RJ45 cable connection and co-located at a maximum of 100 meters.

Typically the two units will be used in conjunction with Virtual Router Redundancy Protocol (VRRP) to achieve seem-less transfer of PTP clients sessions between the two Server units. This is quite important as PTP clients do not to reset their internal clock state-machine which happens when connecting to a new Server. In this case both redundant server units announce the same exact session information upon switchover.

Redundancy is offered in Gateway-Clock and ePRTC Modes.

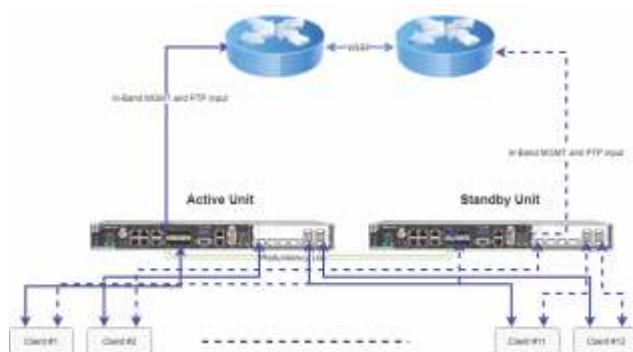

Use case - Aggregation

Accuracy is the relative offset between the active and standby units and is lower than 5 ns relative to the 1 PPS output on the active unit. A single IP management address is used. Health metrics and check mechanisms ensure proper monitoring of units to trigger the redundancy mechanism (switch over event). The redundancy schema is non-revertive. Manual intervention is required if the user decides to switch back to the original active unit once it is back in operation.

Switchover of timing services is very performant. It is completed in less than 3 seconds for any profiles (aside from G.8275.1) with recovery of the full list of connected clients. For the G.8275.1 profile, switchover is performed in less than 0.375 seconds.

Legacy ports have different behaviors than Ethernet. Squelch or Active-Active modes enable the user to decide whether the behavior of the output ports should switch over or not, depending on the user's needs and redundancy strategy.

Redundancy has been extended to the enhanced PRTC (ePRTC) when both active and standby units are set in ePRTC operation mode.

The user now is offered more flexibility for the ports that are dedicated to the redundancy function, not just ETH4.

## Operation Modes

The TimeProvider 4100 series can support multiple modes of operations.

- Gateway Clock mode
- Single Domain High-Performance Boundary Clock mode
- Multi-Domain High Performance Boundary Clock mode of for a fully resilient PTP operation with two active boundary clock instances
- enhanced PRTC mode

Each operation mode is defined by the very specific set of inputs that are used as reference signal reference. But from an outputs standpoint, all features of the a grandmaster clock are available as well as monitoring of external timing inputs.

## Gateway Clock Mode

The TimeProvider 4100 server is a gateway clock, a new class of synchronization product that accepts multiple inputs and generates a variety of outputs using a sophisticated mapping algorithms.

Inputs can be GNSS, SyncE, IEEE 1588 PTP, TOD and E1/ T1 digital transmission links and distributes timing flows to multiple endpoints such as base stations. A gateway clock benefits from multiple layers of protection by leveraging other assets in the core of the network.

The TimeProvider 4100 series supports hybrid operation, which allows the frequency reference to come from only one frequency source (e.g. SyncE) and the time reference to come from another source (e.g., PTP).

Multiple IEEE 1588 PTP enhancements are available in v2.3, including:

- Support for up to three PTP clients with asymmetry correction and majority vote to select the best channel for APTS in Gateway Clock mode
- Support for two PTP server profiles per port
- Support for two timing services per port (both on the main or 1 GbE/10 GbE expansion module)



## High-Performance Boundary Clock Mode

An optional license can enable High-Performance Boundary Clock (HPBC) mode. This mode is used to enable boundary clock with Class C (10 ns) and Class D (5 ns) performance levels.

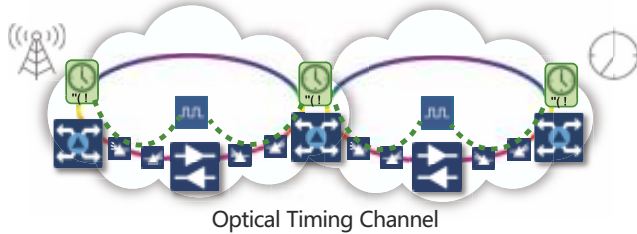

One license can enable two different operation modes: single-domain HPBC (SD HPBC) or Multi-Domain HPBC (MD HPBC).

A typical architecture MD HPBC mode architecture is a horseshoe. An ePRTC placed at each end of the horseshoe transfers precise time to a chain of HPBC units providing PRTC Class A (100 ns) service to gateway clock units. This architecture is redundant as both directions of the horseshoe design can serve as a backup in case of failure in one specific direction.

With single-domain HPBC, the chromatic dispersion calculator was designed for a single PTP client. This has been enhanced in MD HPBC mode to support two PTP clients with respective fiber length fields. Two different chromatic dispersion offset values can be calculated.

## ePRTC Mode

### Mitigates Threat of GNSS Vulnerabilities

Concerned about GNSS vulnerabilities—such as signal anomalies, regional disruptions and even global outages—governments around the world are asking their primary network infrastructure providers to defend against this serious threat. The TimeProvider 4100 series' ePRTC delivers a unique solution that goes far beyond mitigating the threat of GNSS vulnerabilities. It enables an operator to deploy an autonomous time source that is impervious to GNSS disruptions and outages.

### Meets ITU-T G.8272.1 Requirements

ITU-T G.8272.1 specifies the requirements for ePRTCs. This standard describes stringent time, phase and frequency requirements. This specification also requires that an ePRTC has frequency output performance levels that will set the foundation input that can be fed with an autonomous primary reference clock.

Available as an operation mode, the ePRTC enables an operator to configure a TimeProvider 4100 server as an ePRTC device that meets the 30 ns standard's requirement.

Since the ePRTC is available via software upgrade, there's no need to purchase new hardware. Any TimeProvider server produced after July 2019 is factory calibrated to meet PRTC-A, PRTC-B and ePRTC requirements. The server can be upgraded to the latest firmware to operate in ePRTC mode if configured accordingly.

The output signal generator of the TimeProvider 4100 server's ePRTC system provides several formats including PTP, SyncE, 10 MHz, TOD and 1 PPS and traditional timing formats such as E1.

## Cesium Atomic Clock System

The TimeProvider 4100 series' innovative, and high-performance design meets the ITU-T G.8272.1 30 ns accuracy requirement for ePRTC with either a standard cesium atomic clock, such as the Time Cesium 4400/4500 series, or with a high performance Cesium such as the 5071A.

Time Cesium 4x00 and CSIII have one 10 MHz output and one 5 MHz output. 5 Mhz is now supported in addition to the existing 10 MHz signal. Since the TimeProvider 4100 server can sense if the incoming frequency is 10 MHz or 5 MHz, no additional configuration is necessary.

The customer can select the right Cesium source system based on requirements and budget.

## Ensemble Function

The Ensemble function is available when there are two cesium clocks connected to the system. The ensemble algorithm measures and compares the stability of the individual cesium clocks and uses these measurements to produce a higher level of accuracy. Using two cesium clocks also provides operational advantages, as one of the cesium clocks can be removed from service while the system is in operation without any degradation in performance. The ePRTC Output Weight metric for each of the cesium clocks is based on the algorithm quality assessment for each clock. This ePRTC Output Weight metric is visible via CLI and the TimePictra software suite.

## Fully Protected Time Scale

The TimeProvider 4100 series' ePRTC generates time by producing its own autonomous time scale, which provides time, phase and frequency that are aligned and calibrated to the GNSS signal over time. Using patented measurement algorithms, the ePRTC engine evaluates and measures its own autonomous time scale relative to GNSS. It then adjusts its timescale as needed, rather than following the GNSS time regardless of its accuracy. The cesium clocks and GNSS help maintain the accuracy of the ePRTC time scale.

In addition to being used for holdover backup, the local atomic clock provides protection against real-world GNSS events that happen during normal day-to-day tracking operation. The TimeProvider 4100 series' ePRTC has the best protection decoupling in the market, providing a full day of isolation to mitigate real-world jamming and spoofing and unsurpassed detection of anomalous GNSS measurements.

The TimeProvider 4100 series' ePRTC does not simply lock to one atomic clock, but locks to two clocks actively and seamlessly in a properly weighted time scale ensemble. For example, if one atomic clock degrades in performance, the ePRTC will effectively de-weight it from influencing the outgoing time and frequency services.

We provide simple and intuitive dashboard metrics on our ePRTC availability and timescale performance to support proactive management of the ePRTC in your network.

## Holdover Gas Gauge

Based on our extensive expertise in real-life deployments, we know that systems not only need day-to-day protection from GNSS issues, but they also need the assurance that the timescale will support the 14-day holdover requirement.

We maintain a simple Holdover estimate (similar to a gas gauge) so you can know what the current time error accumulation is during holdover and how far they can go until empty

Our product experts and channel partners can assist you with deploying a TimeProvider 4100 server, including enabling the ePRTC mode and setting up the GNSS antenna and cabling

## Independence Between 10 MHz and 1 PPS Outputs

The local oscillator in any clock will need corrections to achieve the desired frequency and time services. In some applications, the same correction is applied to the 10 MHz frequency outputs and the PPS time outputs. This means that the frequency service will have to be overcorrected to maintain coherence time with the 1 PPS output, even though this solution will add noise and possibly cause degradation from the time source.

The time scale in an ePRTC system requires both maximum stability and resiliency for its 10 MHz frequency services without introducing over correction to steer the time. The frequency outputs are optimized for frequency and the time outputs are optimized for time, so there is no need to make extra corrections.

## Security

Secure Shell Protocol (SSH) support and firewall features block specific protocols such as Simple Network Management Protocol (SNMP), SSH, Internet Control Message Protocol (ICMP) and more.

Hardware level security enables to avoid denial of service scenarios for synchronization traffic as well.

New authentication mechanisms are now supported for up to five external servers via TACACS+ and Radius. Full AAA is also available for Radius and TACACS+. Radius also now supports Two-Factor Authentication (2FA).

The new IEEE 1588 2.1 2019 security standard is now supported for two prongs: prong C (Architecture Guidance) and prong D (Monitoring and Management).

Prong C provides more resilient operation of PTP inputs for APTS by using a majority-vote mechanism that also detects tampering of timing packets.

Prong D is used for detection of potential tampering by measuring unusual offsets, PTP link delays and other events.

New SSH extensions can be used to secure a profile. The security level support a Command Line Interface (CLI) or the TimePictra software suite to enable or disable high-security mode.

Common Vulnerabilities and Exposures (CVE) as well as cross-site scripting vulnerability have been addressed thus protecting the unit from these security exposures

## Anti-Spoofing and Jamming

Timeprovider 4100 series is designed to operate seamlessly with an upstream GNSS BlueSky™ firewall for the best GNSS protection. It monitors received signals and performs consistency checks to detect possible attacks.

The multi-band GNSS support introduces two new indicators for monitoring and protection against jamming. The Automatic Gain Control (AGC) and the continuous wave values can be used for guidance on recommended mitigation and actions that are documented in the User Guide.

The TimeProvider 4100 series utilizes advanced algorithms that observe each signal and utilizes knowledge linked to the superior oscillator of the unit compared to data provided by its GNSS receiver. The TP4100 series can detect and mitigate abnormal subtle patterns and offer ultra-high protection of the output timescale.

## Monitoring

The TimePictra software suite offers intuitive feedback for ease of use. The Microchip-branded webGUI that is available on the TimeProvider 4100 server is a user-friendly interface for monitoring results, measurements and calculations. Key benefits include:

- webGUI-based real-time metric updates
- Graphing of any metric vs. user-configured thresholds
- Selectable generic alarm generation for any metrics that support thresholds
- Storage of time metrics for 24 hours
- Support for Time Interval Error (TIE)
- Simple download for every metric (compatible with TimeMonitor)
- 1 nanosecond resolution

Originally developed to help customers with phase deployments, the TimeProvider 4100 series features Time Error calculation for monitoring PTP traffic as well as 1pps monitoring. 1PPS Monitoring is also available.

Monitoring has been expanded to also support legacy monitoring including E1/T1, SyncE and 10 MHz signals. Frequency Time Interval Error (TIE) monitoring, presented as Maximum time interval error (MTIE) is offered for observation periods of 1s, 10s, 100s, 1,000s, 10,000s and 100,000 seconds.

Other enhancements include performance monitoring of multiple PTP clients. SyncE signal monitoring uses the same physical port as PTP monitoring. NTP and PTP Monitoring are also supported on the 1 GbE/10 GbE expansion module ports.

## TDEV support

The TimeProvider 4100 takes advantage of multi-band GNSS support with metrics such as Peak Time deviation (TDEV) noise, which is lower than single-band

## Management

When deployed with our TimePictra synchronization management system, a TimeProvider 4100 server offers superior monitoring information and management capabilities.

It features full Fault, Configuration, Accounting, Performance, Security (FCAPS) capabilities using the Command Line Interface (CLI) and the TimePictra software suite. A separate management port can be selected either as RJ-45 or as an SFP or SFP+ port. In-band management is also supported. Internal logging, SNMP traps and alarms and Light-Emitting Diodes (LEDs) provide additional insight into the status of the unit.

Configuration changes made after an upgrade and before a reboot are now preserved. Support for NTP client and local time assures time alignment for system logs.

A new communication system between the server and the TimePictra software significantly improves system performance and the user experience. It leverages autonomous messaging, which combines status changes or configuration changes without requiring multiple polling messages from the TimePictra software suite.

# Monitoring

This new architecture prescribes:

- Leveraging the existing optical network to avoid using expensive dark fiber
- Using dedicated lambda to transport time in the most rapid way to provide the utmost resiliency
- A redundant source of time based on ePRTC, which can deliver 30 ns performance and use a combination of cesium clocks and GNSS as the source of time
- Offering East and West flows of time to provide a redundant path from source to end point
- Offering a chain of high-precision MD HPBCs that can meet the highest level of performance defined by T-BC Class D 5 ns standards

# Optical Timing Channel

This vPRTC multi-domain architecture is currently the only solution available for delivering affordable, high-performance, state-of-the-art, redundant sub 5 ns distribution of precise time over hundreds of miles optical links, using a state-of-the art Optical Timing Channel (OTC) for highest accuracy.

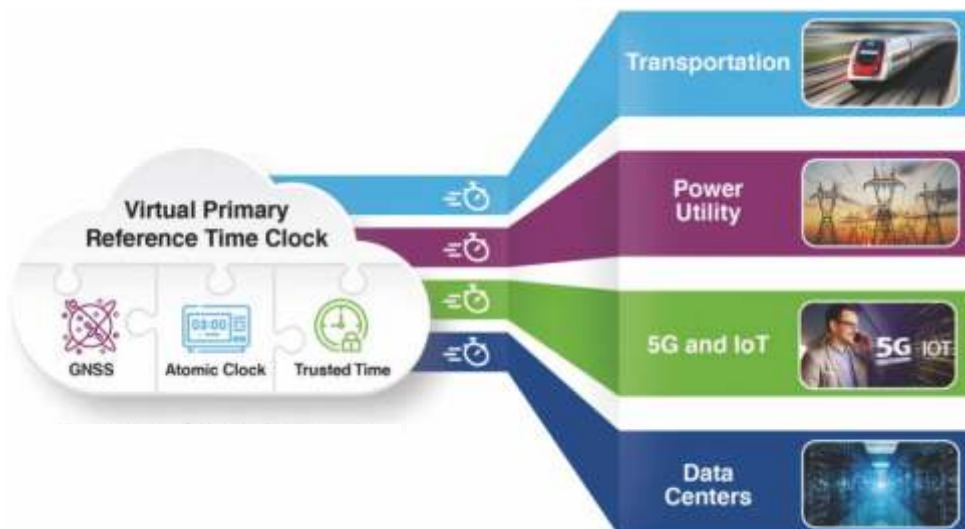
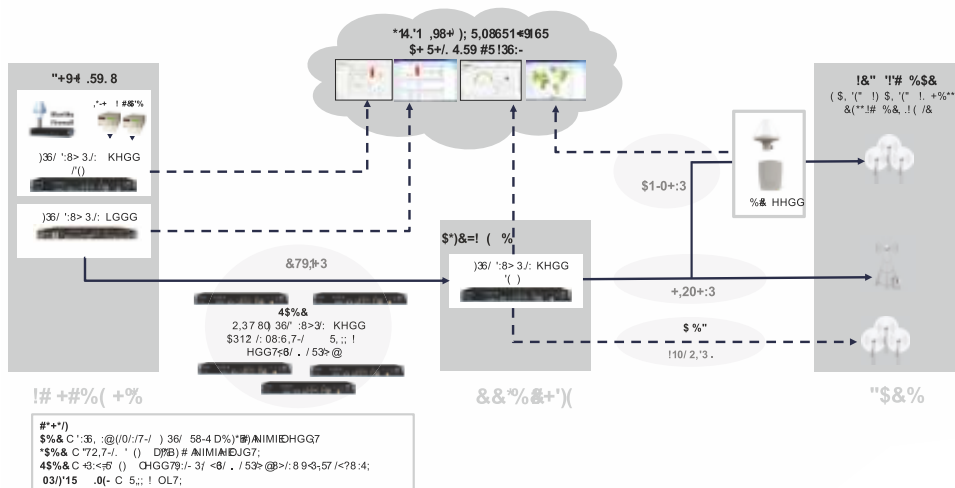

## Specifications

### Mechanical

- Size: 1 RU
- Height: 1.73 in. (44 mm)
- Width: 17.24 in. (438 mm)
- Depth: 9.30 in. (237 mm)
- Depth with connectors on faceplate: 10.07 in. (256 mm)
- 1.75 in. (H) × 17.5 in. (19 in. with handle bracket) (W) × 9.5 in. (10.5 in with BNC connector)
- Rack mounts: 19-inch and 23-inch options with rack adapter sold separately
- Weight: 8 pounds (10 pounds with shipping box)

### Power

- DC power models: dual-power feeds, –38.4 Vdc to –72 Vdc
- Power consumption: OCXO and super OCXO models with DC supply: 28 Watts (max), 20 Watts (typical)
- Rubidium model with DC supply: 35 Watts (max), 28 Watts (typical)

### Oscillator

- Standard oscillator: mini OCXO
- Oscillator upgrade options: OCXO, super OCXO and Rubidium

### GNSS

- Multi-Constellations: GPS, GLONASS, BeiDou, QZSS and Galileo
- SBAS support
- Multi-band support
  - GPS L1/L2C
  - Galileo E1/E5b
  - Glonass L1/L2
  - BeiDou B11/B2I
  - QZSS L1/L2C
- User-configurable GNSS RX survey parameters
- User-configurable AGC and CW range (0%–100% seconds)
- Antenna GNSS cable delay range ±100 (us) GPS over fiber at locations up to 15 miles

### PTP Client (PTP Input)

- Three PTP client inputs with majority vote for best APTS channel selection and Figure of Merit metric
- Two PTP clients in MD HPBC mode of operation
- Profiles: Telecom-2008, ITU-T G.8265.1, ITU-T G.8275.1 and ITU-T G.8275.2
- Best Master Clock Algorithm (BMCA) (IEEE 1588 v2), alternate BMCA (ITU-T G.8275.1/2) and G-BMCA 1.0 (Global Best Master Clock Algorithm)

### Timing Services

- Profiles: Ethernet default, Telecom-2008, ITU-T G.8265.1, ITU-T G.8275.1, ITU-T G.8275.2 and default (IPv4)
- Multiple PTP profiles support per box
- Dual PTP server profiles per port
- Multiple timing services (PTP, NTP, server, client) per port
- G.8275.1 PTP server profile on 10 GbE expansion module is sourced from main unit packet engine per default
- PTP Client list for all ports including 10 GbE expansion module
- Configuration of PTP client load percentage threshold for the entire system with alarm when exceeds
- NTP v4 and v6 and NTPd with MD5 security
- NTP client mode for setting log files – NTPv4&v3 (RFC5905)
  - Up to 10 HMAC keys – MD5, SHA224, SHA256, SHA512, RC4
  - Status in CLI and TimePictra software suite – three NTP servers (configurable)
- NTP or PTP support per port
- Main unit: total of eight ports can operate in parallel with any packet engine services
- In-band or out-of-band management from ETH1, ETH3 or EXP1 ports
- MGT port: ETH1 is capable for PTP client and NTPd timing services. ETH3 and EXP1 are capable of PTP client as well as PTP server and NTPr
- Ports ETH2 and ETH4-8 and EXP1-8 can operate as packet engine services (PTP GM, NTP, PTP probe)
- PTP client timing service can be set on any one of the ports or ETH7 and ETH8 ports together in MD HPBC operation mode

### Timekeeping and Holdover

- Maintains ITU-T G8271.1 400 ns GMC holdover specification for up to 43 hours
- Maintains performance levels for a period until technician can reestablish GNSS or fix the disruption
- Several levels of oscillators (hold 200 ns for full day) to enable remediation
- ITU-T G.8273.4 APTS with enhanced patented automatic asymmetry compensation providing extended phase alignment protection for up to 32 network variations
- Configurable bridging time
- Geographical redundancy through network topology and failover



## ePRTC

- ePRTC ITU-T G.8272.1 30 ns accuracy with support for both 10 MHz or 5 MHz input from cesium clock
- Time reference inputs can be GNSS, ToD-1 and ToD-2
- Frequency Reference inputs can be GNSS, PPS10M-1 and PPS10M-2
- Other references such as, 1 PPS, for monitoring only
- ePRTC ensembling – use of dual cesium feeds in parallel
- ePRTC default bridging period: 14 days, configurable from 5–80 days
- Support for redundancy (with OXCO or better oscillator)
- Provides autonomous time scale for time, phase and frequency that operates even without GNSS availability
- Exceeds requirements as defined by ITU G.8272.1
- Operates with one or two Cesium clock inputs
- PTP IEEE 1588 grandmaster or integration to external grandmasters such as TimeProvider 5000 and TimeProvider 4100 servers
- Meets standard with either standard cesium or high-performance cesium source systems
- Time error in locked mode: accuracy to within 30 ns when verified against the applicable primary time standard (such as UTC)
- Wander in locked mode: better than MTIE and TDEV masks as defined by G.8272.1
- Holdover over 14 days: meets or exceeds 100 ns when verified against the applicable primary time standard (such as UTC)
- Holdover gas gauge
- Intuitive dashboard metrics

## Scalability

- 1,000 PTP clients at 128 pps per box in unicast
- NTPr up to 20,000 tps per port, for a total of 160,000 tps per unit
- NTPd up to 500 tps per port up to three ports for a total of 1,500 tps per unit

## Licensing

- Base unicast client count of 64 clients and software upgrade options through licensing to 128, 256, 512, 790 and 1,000 clients at 128 packets per second
- HPBC license
- NTP license
- Multiband GNSS operation license
- ePRTC license
- Ultra resilience for multi-PTP clients with three PTPc and majorityvote mechanism for enhanced APTS

## Management

- Separate management port from other traffic (such as PTP grandmaster, NTP server and more)
- In-band management (from PTP client interface) IPv4 or IPv6 support for management traffic
- FCAPS on TimePictra platform
- Internal log
- SNMP traps (v2 and v3)
- CLI through SSHv2

- WebGUI through Hypertext transfer protocol secure (HTTPS) for monitoring performance
- Custom CLI banner
- Syslog RFC5424

## Security

- Firewall limits specific protocols such as SNMP, SSH, ICMP and more
- Avoid traffic port denial of service scenarios including sync and announce packet receptions for GM port in hardware level
- Support for TACACS+ AAA
- Maximum five external TACACS+ servers, Name Service Switch (NSS)
- Configuration via SSH or TimePictra software suite
- Support for Radius AAA (maximum five external)
- Radius servers: configuration via SSH or TimePictra software suite
- Support for Radius 2FA
- Support for IEEE 1588 2.1 2019 security prong C (Architecture Guidance) and prong D (Monitoring and Management)
- Vulnerabilities fixed in TimeProvider 4100 series:
  - CVE-2019-15921
  - CVE-2019-15916
  - CVE-2019-10639
  - CVE-2018-20856
  - CVE-2019-8912
  - CVE-2019-11477/11478/11479
  - CVE-2019-5599
  - CVE-2020-11868
- Cross-site scripting
- High-security profile for secured mode configuration (SSH extensions)
- SSH in high-security profile:
  - KexAlgorithms curve25519-sha256@libssh.org,diffie-hellmangroup-exchange-sha256
  - Ciphers chacha20-poly1305@openssh.com,aes256-gcm@openssh.com,aes128-gcm@openssh.com,aes256-ctr,aes192-ctr,aes128-ctr
  - MACs hmac-sha2-512-etm@openssh.com,hmac-sha2-256-etm@openssh.com,hmac-sha2-512, hmac-sha2-256/etc/ssh/moduli: remove all lines with moduli < 2047-bit

## Redundancy

- Software solution
- Two units act as single coordinated system (active/standby)
- Supported in Gateway Clock operation mode or ePRTC operation mode
- Direct fiber and RJ45 connections, less than 100 meters between redundant pair units
- Accuracy: <5 ns relative to 1 PPS output of active unit
- ETH2 (secondary link) and full range of ETH3-ETH8 (main link) redundancy links
- Unique IP address
- Non-revertive schema
- Heartbeat message exchange and clock state sync
- Very performant switch over: < 0.375s for G.8275.1; < 3s for all other timing profiles
- Squelch or On modes for legacy ports

## Class of Service (CoS) and VLANs

- Up to 256 VLANs for PTP server, both for IPv4 and IPv6
- One VLAN for management
- Total number of VLANs is 260 per system (256 PTP server, two PTP client, one management and one spare)

## Time and Frequency Accuracy

- PRTC: fully compliant with ITU-T G.8272
- L1 calibrated PRTC Class B (40 ns)
- Designed with ToD input that is fully compliant with TimeSource ePRTC system
- Frequency accuracy: conforms with ITU-T G.811
- Multi-domain, high-performance boundary clock (MD HPBC) function with G.8273.2 performance [Class C (< 10 ns) and Class D (< 5 ns)]

## Monitoring

- Presentation of network accuracy with all available data through local webGUI
- Four channel measurements
- PTP Packet probing and monitoring with threshold level
- 1 PPS measurement (two channels)
- 10 MHz measurement (two channels)
- E1/T1 measurement (two channels)
- Frequency TIE and MTIE
- MTIE thresholds and alarms support
- Input support for TDEV monitoring, TDEV status and TDEV graphing
- SyncE monitoring on same physical port as PTP
- Up to two SyncE inputs
- Monitoring resolution  $\leq 1$  ns and accuracy  $\leq 2$  ns
- Jitter and wander measurements comply with ITU-T O.172/O.174 for frequency
- Monitoring sample frequency of 40 Hz for up to 100,000 seconds
- NTPv3 and PTP monitoring now supported on expansion module ports

## SyncE

- SyncE can be used as a frequency input and generated as an output (as a parent)
- Conforms to relevant sections ITU-T G.8261, G.8262 and G.8264 Ethernet Synchronization Message Channel (ESMC)
- Automatic SyncE switchover feature in MD HPBC mode
- SyncE switchover between ports
- Extended QL TLV format as per ITU-T G.8264 Amendment 1 (03/2018) clause 11.3.1.1 including enhanced SSM codes

## Physical Interfaces

- Two Gigabit Ethernet ports—shielded RJ45, 100/1000 BASE-T Ethernet
- Six Gigabit Ethernet SFP cages—ports support either:
  - SFP (optical), 1000BASE-X
  - SFP (electrical), 1000BASE-T
- Four E1/T1: two input/output ports and two output ports over balanced RJ48c connectors, 120 $\Omega$ /100 $\Omega$  impedance
- Optional expansion module: 16 E1/T1 output ports over balanced RJ48c connectors, 120 $\Omega$ /100 $\Omega$  impedance
- Optional expansion module: four SFP and four SFP+ for 10 GbE support and 1 GbE or 100M optical fan out
- 16 outputs each separately configurable as E1/T1/2048 kHz/1544 kHz/Composite-clock (64 kHz)/JCC two inputs
- CC-IN1 and CC-IN2 can be configured as CC/JCC inputs to module (outputs phase alignment)
- 1 PPS user-configurable pulse width two 10 MHz/1 PPS input/output ports over single-ended BNC connectors, 50 $\Omega$  impedance
- Two ToD/1 PPS input/output over RJ45 connectors, according to ITU-T V.11-based time/phase distribution interface
- ToD formats: ITU-T G.8271, China Mobile V2, NTP4
- Support for bidirectional SFPs
- Support for G.703 for all physical interfaces including ToD/ E1/T1/10 MHz

## Network Support

- DHCP
- SSHv2
- SNMPv2, SNMPv3
- NTPv3, NTPv4

## Regulatory and Environmental Requirements

### Compliance Marks

- NRTL North America Safety
- CB Scheme International Safety
- CE EU Safety and EMC
- UKCA UK Conformity Assessed
- FCC USA EMC
- VCCI Japan EMC
- RCM Australia/New Zealand EMC
- KC Korea EMC

## Safety Compliance

- UL 62368-1
- CAN/CSA-22.2 No. 62368-1
- IEC 62368-1
- EU Safety Directive 2014/35/EU
  - ✓ EN 62368-1

## Emissions Compliance

- FCC Part 15 (Class A)
- ICES 003 (Class A)
- VCCI (Class A)
- CISPR32
- KN32
- EU EMC Directive 2014/30/EU
  - ✓ EN55032
- Radio Equipment Directive (RED) 2014/53/EU
  - ✓ EN 301 489
  - ✓ EN 303 413
- EN 300 386

## Immunity Compliance

- Kn35 (Criteria A)
- EU EMC Directive 2014/30/EU
  - ✓ EN55024

## Environmental

- Acoustic noise level: 0 dBA
- Operating temperature: -5°C to 55°C for Rb, -5°C to 65°C for mini OCXO, OCXO and super OCXO
- Storage temperature: -40°C to 70°C
- Relative humidity: 5% to 90% non-condensing, 100% with condensation under ETSI EN 300 019-2-3 T3.2
- ETSI EN 300-019-2-3, Operating, Class T3.2
- ETSI EN 300 019-2-2 (1999) – Transportation, Class T2.3
- ETSI EN 300 019-2-1 (2000) – Storage, Class T1.2
- GR-63
- Ingress Protection Rating: IP20
- RoHS EU Directive 2011/65/EU and the (EU) 2015/863 amendment

## Network Equipment Building System

NEBS Level 3\*, GR-1089

\*When following deployment guidelines as specified in the user manual

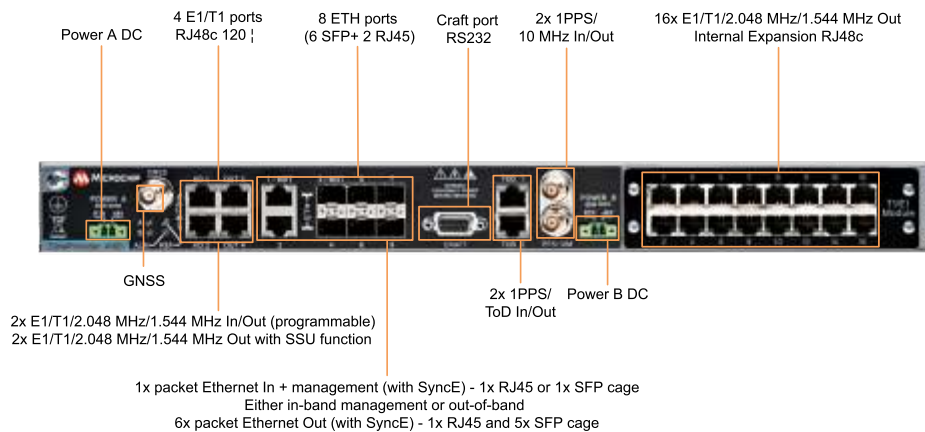

## TimeProvider 4100 Server With 10 GbE Module Physical Outline

