

TimeProvider 5000

IEEE 1588-2008 PTP Grandmaster Clock



TimeProvider® 5000 is an IEEE 1588-2008 standard-compliant grandmaster clock with a carrier-grade design that provides high client capacity, hardware-based packet processing, and redundant hardware to deliver scalable performance and maximum network availability. When locked to a GNSS input, the TimeProvider 5000 meets the applicable performance requirements of the ITU-T G.8272 standard for a primary reference time clock (PRTC).

With dual input/output clock cards in active and standby mode, TimeProvider 5000 ensures that there is no impact on client performance when failover occurs. Redundant cards provide protection far superior to network redundancy models in which clients must re-acquire synchronization from a different grandmaster somewhere else in the network.

Protection of the input clock source has become increasingly important. TimeProvider 5000's new IMC card has support for dual GNSS inputs. In addition, TimeProvider 5000 supports auto-switching of the input source between E1/T1 and GPS based on clock quality-level and user-priority settings.

With hardware-based time stamping and packet processing, TimeProvider 5000 delivers high client capacity at full rates up to 128 messages per second with performance that does not degrade as the number of clients increases.

TimeProvider 5000 supports user-configurable PTP profiles, including default, Telecom-2008, ITU-T G.8265.1, ITU-T G.8275.1, ITU-T G.8275.2, and hybrid profiles. PTP profiles can be configured to operate as IPv4 or IPv6. Support for multiple standard profiles ensures full interoperability with clients in multi-vendor environments. Synchronous Ethernet output is also supported with full traceability and ESMC support.

With optional NTP server capability, TimeProvider 5000 supports multiple vendors and protocols found at mobile network base station sites. Both PTP and NTP protocols operate simultaneously with PTP- and NTP-based clients. The two ports of an IOC card can be separately configured, one for PTP and one for NTP, allowing the standby IOC card to protect for both protocols. NTP capacity is up to 120,000 transactions per second (TPS), and PTP capacity remains at up to 1000 clients.

TimeProvider 5000 serves as the initial unit in a "rack and stack" configuration with TimeProvider Expansion products. These units add capabilities to the TimeProvider portfolio. Each TimeProvider Expansion10 adds 16 Ethernet ports that support SyncE as well as PTP, while each TimeProvider Expansion30 adds 12 E1 and 12 1PPS/TOD ports.

FEATURES

- Redundant hardware: inputs, outputs, clock, and power
- Hardware-based packet processing
- User-configurable PTP profiles with IPv4 and IPv6 support
- Supports the latest ITU PTP profiles including ITU-T G.8265.1, ITU-T G.8275.1, and ITU-T G.8275.2
- ITU-T G.8272 PRTC
- Synchronous Ethernet support with optical SFPs
- Single or dual GNSS inputs with GPS, GLONASS, Galileo, and Beidou options
- Input source priority auto-switching
- PTP and carrier-grade NTP server (optional)
- PTP probe for PDV measurement (optional)
- Management through CLI, SNMP v2c/v3, TimePictra PTP probe licensed software option

BENEFITS

- Fully interoperable with standardsbased clients
- Highly scalable PTP grandmaster supports up to 2000 PTP clients at full 128 messages per second rate
- No performance degradation as client capacity grows
- Simultaneously supports both PTP and NTP elements in the network
- Capabilities grow with TimeProvider expansion products

APPLICATIONS

- Wireless Ethernet backhaul
- LTE, LTE-Advanced, and 5G synchronization
- Circuit emulation services (CES)
- Passive optical networks (PON)
- Femto cells and small cells

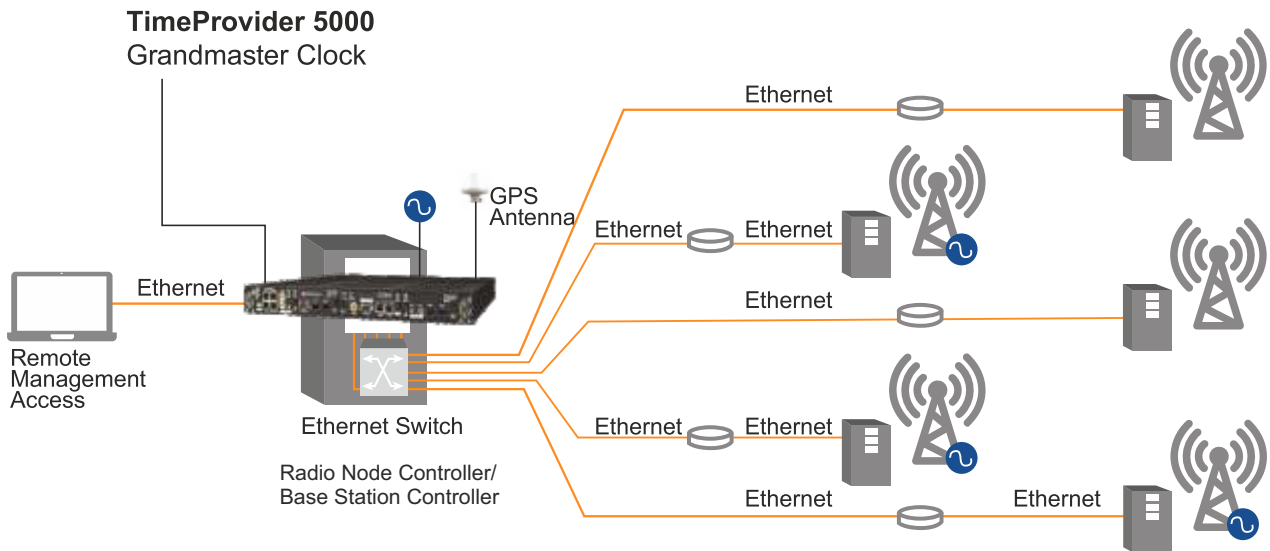

SPECIFICATIONS

GNSS Input Options

- Single or dual GNSS input card options
- GPS, GLONASS, Galileo and Beidou support options
- L1 band antenna

Inputs

- 2 × E1 (2.048 Mbps and 2.048 MHz)
- 2 × T1 (1.544 Mbps and 1.544 MHz)
- 2 × 1PPS and TOD

Outputs

- 2 × GigE output per IOC (optical and electrical) supporting PTP, NTP, and SyncE
- 4 × E1 (2.048 Mbps and 2.048 MHz)
- 2 × T1 (1.544 Mbps and 1.544 MHz)
- 1 × 10 MHz
- 1 × 1PPS

Physical Specifications

- Dimensions: 44 mm (H) × 483 mm (W) × 435 mm (D) (1.75" H × 19" W × 17" D)
- Weight: 4.4 kg (9.6 lbs)

Power Requirements

- -38.4 VDC to -75 VDC (dual redundant) at 43 W typical

Environmental Specifications

- Operating temperature: -5°C to +45°C
- Storage temperature: -40°C to +70°C
- Humidity: 5% to 100% with condensation

GNSS Input Options

- I/O module (includes 4 × I/O ports)
- IMC module
- IOC (Quartz) module
- IOC (Rubidium) module

Time Stamp Precision

- <10 ns RMS typical

Frequency Accuracy

- Tracking to GPS: PRS/PRC quality
- Holdover (over constant temperature): Rubidium (G.812 type II) $1 \times 10^{-11}/\text{day}$ Quartz (G.812 type I) $1 \times 10^{-10}/\text{day}$

Time Accuracy

- Tracking to GPS: <100 ns when locked to GPS, PRTC-compliant

Holdover Performance

Oscillator	200 ns	400 ns	1.1 μs	1.5 μs	5 μs	10 μs
OCXO	4 hrs	8 hrs	13 hrs	15 hrs	1.2 days	1.7 days
Rubidium	15 hrs	1 day	2 days	2.6 days	8 days	12 days

Note: This table lists typical (1 sigma confidence) values. Assume a benign temperature environment. TimeProvider 5000 is assumed to be powered-up for 3 weeks and locked for 96 hours.

Client Capacity

- PTP (base): 500 clients per port, 1000 per IOC card
- PTP (optional): 1000 clients per port, 2000 per IOC card
- Supporting full 128 PTP messages per second rates at peak 1000/2000 client capacity (L3, unicast)
- PTP with NTP option
 - One port with PTP: 1000 clients
 - One port with NTP: up to 120,000 transactions per second

NTP Server Option

- Stratum 1 server through GNSS
- Up to maximum 120,000 transactions per second

PTP Probe Option

- PDV measurements
- Supports L3 unicast, L3 multicast and L2 multicast

Other SW License Options

- 2000 PTP client capacity license
- 500 VLAN license (PTP only)
- L2/L3 multicast PTP and two-step clock license
- NTP server with 20,000 TPS license
- NTP server with 120,000 TPS license
- TimeProvider Expansion10 16 port license (adds availability of ports 9–16 to standard 8 ports)
- PTP port IPv6 support
- GNSS license (enables GLONASS, Galileo, and Beidou on 090-50331-06 and 090-50331-07 IOC cards)

Management

- IPv4 or IPv6
- CLI
- SNMP v2c, v3 (optional)
- TimePictra (purchased separately)

Industry Standards/Requirements

- ITU G.811, G.812, G.823, G.8261, G.8272
- G.703, G.704, ETSI 300/Class 3.1

Client Capacity

- IEEE 1588-2008 (PTP)
- NTPv4 (optional)
- IPv4 (IPv6 optional)
- DHCP
- SFTP, FTP
- DiffServ/DSCP
- VLAN (up to 16 for PTP, 1 VLAN for NTP)
- TELNET
- SYSLOG
- RADIUS
- SSH

Certifications

- CE Mark certified
- EMC Directive 2014/30/EU
 - CISPR32/24
 - Radio Equipment Directive (RED) 2014/53/EU
 - EN 300 440 and EN 303 413
 - FCC part 15, ICES-003, AS/NZS Class B, ETSI 300 386
 - V1.6.1, EN55032/24, KN32/KN35, VCCI
 - NEBS GR-1089
- Environmental
 - NEBS GR-63
 - ETSI 300 019-1, -2 -3
- Safety Directive 2014/35/EU
 - UL/cUL 62368-1, IEC 62368-1 CB, EN62368-1 2nd edition
 - RoHS 6 of