

# SSU 2000/SSU 2000e

## Synchronization Supply Unit (SSU) for Carrier-Grade Networks



SSU 2000

SSU 2000e

The Microchip SSU 2000 and SSU 2000e are fully manageable synchronization systems used by communications network operators to generate and distribute superior synchronization signals for their networks. The SSU 2000 conforms to ANSI standards and is NEBS certified, while the SSU 2000e is ETSI certified. Both systems use the same plug-in cards.

The SSU 2000 and SSU 2000e use the latest hardware and software integration technologies to provide a complete synchronization system for current and future network needs.

### High Capacity, High Availability Architecture

The SSU 2000/SSU 2000e architecture is designed to integrate intelligent, functional cards into a flexible, fully redundant system to satisfy current capacity and synchronization technology requirements and allow incremental capacity growth and deployment of new capabilities with additional plug-in cards as they are needed.

The SDU 2000/SDU 2000e Synchronization Distribution Unit (SDU) expansion shelves connect to a corresponding SSU 2000/SSU 2000e main shelf to provide additional output signals. The expansion shelves use the framing and synchronization features of the main shelf to drive an array of output cards: any combination of T1, E1/2048 kHz, and Composite Clock output cards.

T1 and E1 output cards may be configured in redundant pairs providing 20 1+1 fully protected outputs per pair. A fully configured SSU 2000 system provides T1/E1 output total capacity of up to 1280 unprotected ports or 640 protected ports. A fully configured SSU 2000e system supports up to 460 protected or unprotected ports.

Frequency input signals are passed through in case of multiple internal failures, including clock failures. The shelves accept dual DC power and provide independent power conversion on each card. All cards are individually fused to protect the system in case of a short circuit on any one card.

### KEY FEATURES

- High capacity, modular system
- Integrated GNSS (GPS and GLONASS)
- E1, T1, CC outputs
- RADIUS, SSH option
- Performance monitoring on all inputs
- Management: TL1 and ICS, option for SNMP
- TimePictra Synchronization Management System support

### KEY BENEFITS

- Fully redundant for service delivery protection
- Proven interoperability
- High capacity E1 and T1 ports

### KEY APPLICATIONS

- Primary Reference Source (PRS), PRC based on Global Navigational Satellite System (GNSS)
- SSU, Building Integrated Timing Supply (BITS), Stand Alone Synchronization Equipment (SASE), Timing Signal Generator (TSG)
- SDH/SONET, Ethernet, GPON networks
- 2G/3G and 4G/LTE networks
- Telecommunications, power utility, government, and other private network

## Industry Standards Compliance, NEBS Level 3 Certification

The SSU 2000 and SSU 2000e are designed to meet the latest and evolving industry standards, including ANSI, Telcordia, ITU-T G.811, G.812, G.823, G.703, G.704, ETSI, and CE. The SSU 2000 is fully Network Equipment Building System (NEBS) Level 3 certified.

## Intelligent Cards

Each card has an integrated CPU with software for superior reliability, flexibility and functionality. Cards can be hotswapped while the unit is operating without any degradation of the output signals. Each intelligent card supports the management of critical, major and minor alarms. Powerful management can be performed to and within each card through the communication card, including in-service upgrades of software and programmable logic devices.

**Auto-reconfiguration:** If a card is removed and a like card installed in the same slot, the new card will be automatically configured to the same settings as the previous card.

## GNSS Cards

The SSU 2000/SSU 2000e integrates single or dual satellite system receiver cards to meet primary reference clock requirements. Integrated capability delivers these key benefits:

- Flattens the number of levels in the synchronization distribution hierarchy
- Improves the overall performance of the network
- Lowers the overall OAM&P costs (Operation, Administration, Maintenance, and Provisioning).
- Single unit PRS

Two cards are available: The GNSS card supports GPS and GLONASS signals and can be locked to either one or both simultaneously. Also available is a dedicated GPS-only card.

## Input Cards

The SSU 2000 accepts up to nine input cards; the SSU 2000e accepts up to three input cards. The platform supports the following input signals:

- T1 (framed)
- E1 (framed)
- SSM quality
- JSW and JCC (Japan)
- 1 MHz (sine or square)
- 1.544 MHz (sine or square)
- 2.048 MHz (sine or square)
- 5 MHz (sine or square)
- 10 MHz (sine or square)

In the SSU 2000e each input slot supports connections for termination, bridging, monitoring and traffic pass-thru. These connectors provide performance monitoring, impedance termination and traffic pass through to network elements and input references.

Various input impedance panels are available for the SSU 2000 to support the following balanced or unbalanced signal impedances:

- 50 ohms (sine)
- 75 ohms (T1/E1)
- 100 ohms (T1)
- 120 ohms (E1)
- 133 ohms (CC)
- High impedance for timing extraction only (bridging mode)
- Panel/adaptor connection interfaces:
  - Wire wrap
  - BNC
  - DE-9

Input signals are passed through to corresponding outputs in case of multiple internal failures, including clock failures.

## SSU 2000/SSU 2000e Block Diagram

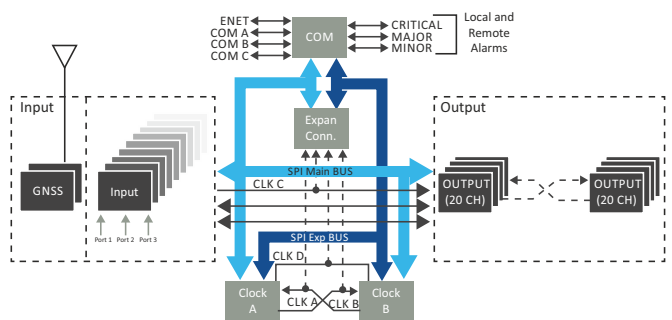

## Intelligent Clock Cards, Superior Holdover Performance

The SSU 2000/SSU 2000e accepts single or dual clocks. Three clock cards are available to meet different international standards and specific holdover requirements: ITU-T Type 1 (ETSI Slave Clock, enhanced quartz oscillator), Type II (Stratum 2E, enhanced rubidium oscillator), and Type III (Stratum 3E, enhanced quartz oscillator). Redundant configurations may use a mix of technologies. In case of loss of GNSS and input references, the SSU 2000/SSU 2000e uses intelligent software to provide enhanced output performance beyond the required holdover stability. Its superior holdover capability retains stratum G.812 performance for three weeks during holdover conditions with Microchip rubidium technology.

## Output Cards

The SSU 2000's main shelf supports 8 output cards, providing up to 160 unprotected outputs. Up to four expansion shelves can be added, providing up to 1120 additional unprotected output ports. The output cards may be configured for redundant operation.

The SSU 2000e's main shelf supports up to 6 output cards, providing up to 60 protected or unprotected output ports. Up to four expansion shelves can be added, providing up to 400 additional protected or unprotected output ports.

Any output card can be removed or inserted while power is applied without affecting the operation of any other card or the system. Various output cards are available to meet specific signal and interconnection requirements including T1, E1, CC, JCC, and JSW. The activation of the output ports are fully user controllable.

## E1/2.048 MHz Output Card

The E1/2.048 MHz output card has 20 ports that are software selectable for either E1 or 2.048 MHz output signals. The E1 signal has a multiframe format, with selectable Channel Associated Signaling (CAS) or Common Channel Signaling (CCS).

## T1 (DS1) Output Cards and Capabilities

The T1 output card has 20 ports. The T1 output card generates phase-locked output signals of 1.544 MHz

## Composite Clock Output Card

The Composite Clock output card generates 20 signal pairs (TIP and RING signal pairs). Each output is a transformer-coupled symmetrical pair. Each output pair can be turned off independently of other channels. Relays on each output allow for disconnecting the driver output from the output pins.

## Connectivity

For the SSU 2000, there are a variety of input and output panels available with several types of connectors. These include DE9, wire-wrap and BNC type connectors. Also available are high density wire wrap panels in both 80 and 100 output versions. For the SSU2000e, DE9 connectors are included in the shelf design.

## Synchronization Status Messages (SSM)

The input card reads and processes SSM in accordance with ITU-T and ANSI standards to determine the traceability of inputs. This traceability information is then used by the clock cards in selecting a reference signal, and is embedded into the system's outputs. An embedded, editable table allows upgrades as standards evolve.

## Communications, Management and Security

The SSU 2000/SSU 2000e operates with a single communications card, with enhanced security and SNMP. The communications card supports TL1 and the Interactive Command Set (ICS), ASCII management interfaces. Coupled with Microchip's advanced management software solutions, the communication module provides powerful fault, configuration, accounting/inventory, performance, security, and other optional management functions.

Network administrators can schedule automatic firmware upgrades. System firmware in the master and expansion shelves can be scheduled for automatic updates without further human intervention. Using a secure FTP (SFTP) connection, the communications card can automatically download firmware from a remote server to upgrade the SSU 2000/SSU 2000e system. The Comms R card has NTP client functionality, making it easy to set the system log times to align with an NTP server. Two system images can be stored on the card, giving the user the ability to update or revert to a standby image with a simple command.

## RADIUS, SSH, and SFTP option

The communications card supports optional security features such as support for Remote Authentication Dial-In User Service (RADIUS) authentication, Secure Shell (SSH) and Secure File Transfer Protocol (SFTP). This option was designed for environments where secure access to network elements is critical. Using SSH-encrypted client authentication and up to 32 characters for user ID and password access, it enables communication with a centralized server to authenticate remote users and authorize their access to the SSU 2000/SSU 2000e system. Four access levels (user, technician, supervisor or administrator) and automatic logout provide superior security access to the system, ideally suited to enterprise and international gateway deployments where secure remote access is required. Also included in this software option is support for SNMP v2 or v3

## TimeCraft

Available to support the SSU 2000/SSU 2000e, TimeCraft is an easy-to-use Graphical User Interface (GUI) management tool that reduces the complexity of using TL1 or ICS commands. Its intuitive GUI allows the operator to supervise and control a network element either remotely or locally through icons and simple point and click operations.

TimeCraft capabilities include support for remote firmware upgrades and provisioning to the port level, event-driven fault management, physical and logical configuration management, and performance and security management.

## TimePictra

The SSU 2000/SSU 2000e is fully supported by Microchip's TimePictra advanced Synchronization Management System. TimePictra provides full FCAPS capabilities (fault, configuration, accounting/inventory, performance and security) as well as an array of advanced management features.

## Microchip Global Services

Microchip provides synchronization services that assist customers with the planning, deployment and maintenance of synchronization infrastructure. Services are designed to help lower costs, streamline processes, ensure quality, and deliver the highest level of performance from your synchronization network.

The Platform Maintenance service bundles together Microchip's industry leading technical support along with all software maintenance. As part of Platform Maintenance, customer will receive all updates as well as all upgrades including all patches, point releases, maintenance releases and related documentation for your purchased version of software during the contract period.

## SSU 2000 Access Using RADIUS Authentication

- 1 User requests access to SSU 2000 (using SSH protocol)
- 2 SSU 2000 requests user authentication from RADIUS server
- 3 RADIUS server authorizes user access
- 4 User communicates with SSU 2000 (using SSH protocol)

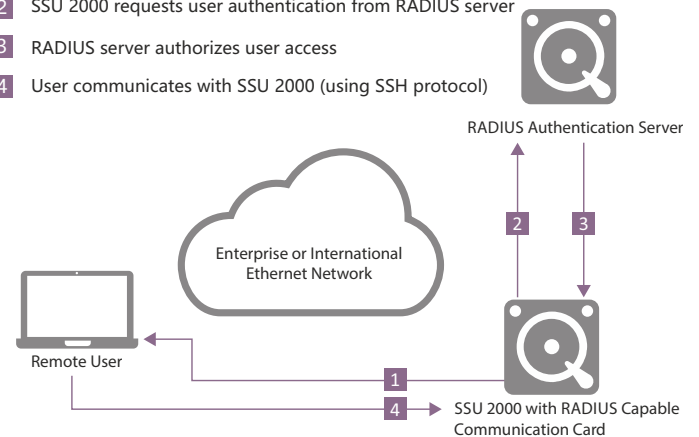

## Specifications

### Shelf Architecture, Capacity

#### SSU 2000 System

- SSU 2000 Main Shelf, 12 slots: 2 clock, 1 communication, 9 for either input or output cards.
  - 27 total maximum input ports
  - 160 total maximum unprotected output ports
  - 80 total maximum protected output ports
- SDU 2000 Expansion Shelf, 16 slots: 2 buffer cards, 14 output cards System supports 4 expansion shelves. The last expansion shelf in the chain can be located up to 200 feet away from the main shelf.
  - 280 total maximum unprotected output ports per shelf
  - 140 total maximum protected output ports per shelf
- SSU 2000 system total output capacity (main shelf plus 4 expansion shelves)
  - 1280 total maximum unprotected output ports
  - 640 total maximum protected output ports

#### SSU 2000e System

SSU 2000e Main Shelf: 12 slots: 2 clock, 1 communication, 3 input cards, 6 output cards.

Output slots are pre-wired for redundant pairs.

- 9 total maximum input ports
- 60 total maximum protected or unprotected output ports

SDU 2000e Expansion Shelf, 12 slots: 2 buffer cards, 10 output cards.

System supports 4 expansion shelves. Output slots are prewired for redundant operation. The last expansion shelf in the chain can be located up to 60 meters away from the main shelf.

- 100 total maximum protected or unprotected output ports
- SSU 2000e system total output capacity (main shelf plus 4 expansion shelves)
  - 460 total maximum protected or unprotected output ports

### Input

#### Input Card Types

- T1 framed, 1/1.544/2.048/5/10 MHz sine or square wave, user settable
- E1 framed, 1/1.544/2.048/5/10 MHz sine or square wave, user settable
- Composite Clock
- 1.544 MHz or 6.312 MHz sine wave (Japan)
- Composite Clock (Japan)
- GNSS (GPS and GLONASS)
- GPS only

#### Input Capabilities

- Embedded Sync Status Messaging (SSM)
  - Compliant with SSM specification per T1X1.3 TR33, ANSI T1.101-1999, ITU-T G.704, and Telcordia GR-253-CORE
- Integrated performance measurements (TIE, MTIE, TDEV, ERROR RATES) on all inputs
- Selection mode: Priority, SSM, Performance Mask
- Real time CPU: Intelligent software for real-time MTIE, TDEV and TIE performance monitoring.

#### GNSS/GPS Cards

- Integrated single or dual (protected input) cards
- Compliant with Stratum 1 PRS (Primary Reference Source) per ANSI T1.101-1999, ITU-T G.811, Telcordia GR2830/1244-CORE, and ETSI EN300 462-

### Performance Measurement

#### Resolution

- Measurements are provided for each input versus each clock at a resolution of 1 ns

#### Sampling Rate

- 40 Hz for all frequency cards
- 1 Hz for GNSS/GPS cards
- 1 Hz averaging

### Calculations

#### MTIE

- Meets or exceeds the latest ITU-T, ANSI and Telcordia standards with measurement intervals of 0.05 to 100,000 seconds. GNSS/GPS is 1 to 100,000 second

#### TDEV

- Exceeds the latest ITU-T, ANSI and Telcordia standards with measurement intervals of 0.1 to 10,000 seconds.

#### Phase

- 1, 100, 1000, and 10,000 second phase averages and history are available.

#### Frequency

- Frequency measurements can be viewed via user selectable calculation periods from 10 to 10,000 seconds.

## Clock

### Clock Card Types

- Enhanced Rubidium, Stratum 2E Type II
- Enhanced Quartz, Stratum 3E Type III
- Enhanced Quartz, Type I for ITU-T standards

### Clock Performance

- Compliant with clock levels per ANSI T1.101-1999, ITU-T G.812, Telcordia GR-2380/1244-CORE and ETSI EN300 462-4

### Control

- DDS (Direct Digital Synthesis) technology for cost-effective calibration-free operation and precise frequency control

## Output

### Output Card Types

Signal outputs meet ITU-T G.811 after SSU is locked to Cesium or GNSS input reference and compliant with SSM specification per ITU-T G.704

All frequency cards have 20 output ports

- T1 (DS1)
- E1, port selectable 2.048 MHz/2.048 Mbps

## Specifications

- Composite Clock
- Sine Wave, 1.544 MHz or 6.312 MHz (Japan)
- Composite Clock (Japan)

### Redundancy

- 1+1 output protection (both cards active)

## Communication and Management

### Management

- The SSU 2000/SSU 2000e is a fully automated and software manageable system. Firmware upgrades can be remotely installed.

### Communications Card Ports

- RS-232 (EIA-232)
- Ethernet, 10Base-T, and 100 Base-T

### Management Interface Protocols

- Simple fault, visual & contact closures
- TCP/IP, IPv4
- TL1
- Interactive Command Set (ICS), ASCII
- SNMPv2, SNMPv3 (optional)

RS-232 ports support ASCII and TL1, and Ethernet port supports all of the above. The Ethernet port supports four telnet sessions, two TL1 sessions, and five SNMP messages

### Event Log

- Stores up to 1000 events from any system faults, user interventions, and system actions. Events are time & date stamped to less than 1 msec.

### Security

- RADIUS authentication (optional)
- Secure Shell (SSH) (optional)
- Secure FTP (SFTP)
- User ID length: up to 32
- User password length: up to 32
- User access levels: 4

## Management Software

Available management programs (see separate datasheets)

- TimeCraft Windows GUI-based local management terminal
- TimePictra Synchronization Management System

### Power

- Dual -38 to -75 Vdc
- SSU 2000: Less than 120 watts power consumption per shelf
- SSU 2000e: Less than 100 watts power consumption per shelf

### Size (H xW xD)

- SSU 2000: 10.5" x 17" x 11.5" (26.7 cm x 43.2 cm x 29.3 cm)
  - SSU 2000e: 19.6" x 17" x 9" (50 cm x 43.2 cm x 22.9 cm)
- Widths do not including mounting ears

### Weight (provisioned)

- SSU 2000: approx. 27 lbs (12.3 kg) main unit
- SSU 2000e: approx. 27 lbs (12.3 kg) main unit

### Environmental

- Operating temperature: -5°C to +55°C
- Storage temperature: -20°C to +75°C
- Relative humidity: typically 93% at 30°C, non condensating
- GR 63

### Environmental and Safety Compliance

#### EMC

- Telcordia NEBS Level 3 certified
- ATT TP-76200/76450
- VZ.TPR.9305
- FCC part 15 class A USA, ICES-003 class A Canada, VCCI Japan, AS/NZS, KN32/35 Korea
- ETSI 300 386 V-1.6.1: CISPR32, EN55032, ETSI 300 132-2
- SSU2000e 1TR9 class B
- RED 2014/53/EU: EN303 413, EN301 489

#### Immunity

- ETSI 300 386 V-1.6.1: CISPR24
- EN55024: ESD, EFT/B, Surge, Conducted Immunity, Radiated Immunity

#### Safety

- UL 62368-1, CSA C22.2 no. 62368-1
- IEC/EN 62638
- CE Mark
- RoHS Compliant 6/6